

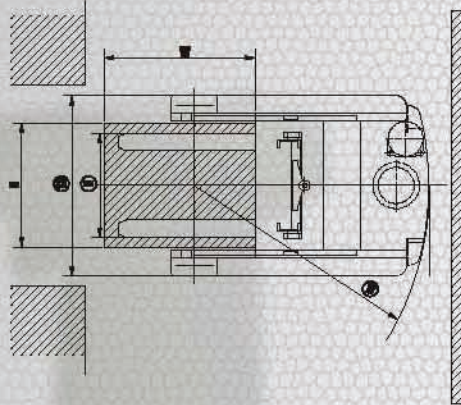

DIMENSIONS



H Series Reach forklift specification

General											
		CQD12H	CQD12H-C1	CQD14H	CQD14H-C1	CQD16H	CQD16H-C1	CQD20H	CQD20H-C1		
1	Manufacture										
2	Model										
3	Power type	Battery		Battery		Battery		Battery			
4	Rated capacity	kg	1200	1400	1600	2000					
5	Load center	mm	600	600	600	600					
6	Lift height	mm	3000	3000	3000	3000					
7	Free lift height	mm	340	340	340	340					
8	Fork size	L x W x T	mm	920x100x36	920x100x36	920x100x36	920x100x36				
9	Fork spread(outside)	Min. / Max.	mm	220 / 896	220 / 896	220 / 896	220 / 896				
10	Mast tilt range	F / R	deg	2 / 4	2 / 4	2 / 4	2 / 4				
11	Axle centre of fork face		mm	390	390	330	330				
12	Overall dimensions	Length to face of fork	mm	1802	1802	1802	1882				
13		Overall width	mm	1240	1240	1240	1272				
14		Mast lowered height	mm	2100	2100	2100	2100				
15		Mast extended height	mm	3585	3585	3585	3585				
16		Overhead guard height	mm	2075	2075	2075	2075				
17	Turning radius(outside)		mm	1876	1876	1876	1766				
18	Min. right angle stacking aisle width (Ast)	Pallet W x B=1200 x 1000	mm	2826	2826	2826	2906				
19		Pallet W x B=800 x 1200	mm	2600	2600	2600	2680				
20	Speed	Travel	Km / h	10.2	10.2	10.2	10.2				
21		Lifting (Full load)	mm/sec	280	280	220	210				
22	Extend distance		mm	602	602	542	542				
23	Max. Gradeability (Full load)		%	10	10	10	10				
24	Self weight		kg	2860	2860	3000	3260				
25	Wheels (diameter*width)	Front	mm	285 x 100	285 x 100	285 x 100	343 x 108				
26		Drive	mm	343 x 114	343 x 114	343 x 114	343 x 114				
27	Wheelbase		mm	1420	1420	1420	1500				
28	Ground clearance		mm	70	70	70	70				
29	Battery	Model		D-400B	D-400B	D-500	D-500				
30		Voltage / Capacity (5 HR)	V / AH	48 / 400	48 / 400	48 / 500	48 / 500				
31		Weight (with box)	kg	760	760	900	900				
32	Electric motors	Drive	Model	XQ-5H-1	XQ-5H-1	XQ-5H-1	XQ-5H-1				
33			Rated output / r.p.m	kw	5.4 / 1680	5.4 / 1680	5.4 / 1680	5.4 / 1680			
34		Load	Model	XQD-7.5-2H	XQD-7.5-2H	XQD-7.5-2H	XQD-7.5-2H				
35			Rated output / r.p.m	kw	7.5 / 2000	7.5 / 2000	7.5 / 2000	7.5 / 2000			
36	Control	Manufacture		CURTIS	CURTIS	CURTIS	CURTIS				
37		Type		DC	AC	DC	AC				
38	Operating pressure	For attachments	MPa	14.5	14.5	14.5	14.5				

1. Special lifting height available (2.7m, 3.5m, 3.8m, 4m, 4.3m, 4.5m, 4.8m, 5m, 5.5m, 6m, 6.5m, 7m, 7.5m).

2. Attachment available.

3. Battery charger available.

4. The specification in this table are for standard models only. For further information please contact us.

5. Specification are subject to change without notice.